

SINGLE-ELECTRON TRANSISTOR EFFECT IN A TWO-TERMINAL STRUCTURE

S. V. Vyshenski¹⁾

Nuclear Physics Institute Moscow State University, 119899 Moscow, Russia

*Research Center for Quantum Effect Electronics,
Tokyo Institute of Technology, 2-12-1, Tokyo 152, Japan*

Submitted 2 September, 1997

A peculiarity of the single-electron transistor effect makes it possible to observe this effect even in structures lacking a gate electrode altogether. The proposed method can be useful for experimental study of charging effects in structures with an extremely small central island confined between tunnel barriers (like an $\simeq 1$ nm quantum dot or a macromolecule probed with a tunneling microscope), where it is impossible to provide a gate electrode for control of the tunnel current.

PACS: 73.23.Hk, 73.61.-r

By definition, a device called a "transistor" should have three terminals. One of them (the gate) is meant to control the current flowing between the other two. The same can be said for the case of a single-electron transistor (SET). The main objective of this paper is to prove that just two terminals are sufficient for studying the SET effect in experiment, provided that the voltages applied to these two are held in a special way. Thus in the particular case of the SET, the transistor effect (TE) can be studied in systems which are not transistor devices. Although this simplification may be of no immediate use for the electronics industry, it is of importance for basic physical experiment. Here interesting and physically rich mesoscopic systems can be prepared artificially [1] or grown naturally [2]. But the nanometer size of these systems makes fabrication of the gate another challenging problem (if it is feasible at all).

We illustrate the main idea using as an example the semi-classical "orthodox" approximation [3] for the description of the SET dynamics of systems with a purely conductivity between tunnel metallic electrodes. In the closing section we argue that the same two-terminal method is much more generally applicable.

Consider the charge-quantized double-barrier structure in Fig. 1, which is called a SET. The total charge ne confined on the central island is a good macroscopically observable quantum number provided that $e^2/C \gg k_B T$ and $R_{1,2} \gg \hbar/e^2 \simeq 4.1$ k Ω , where $C = C_0 + C_1 + C_2 + C_g$. Traditionally a gate with a capacitive coupling C_g is present and allows for modulation of the current flowing between terminals V_1 and V_2 . The modulation is due to the change in charge induced on the central island by a change in the gate voltage V_g . This is the conventional TE.

The gate may be absent from a particular structure. In Fig. 1 this case is indicated by the dashed lines around the gate. Here we can get the same modulation effect by making use of a "hidden" gate, which is the self-capacitance C_0 of the central island. For this we introduce a common background $-v$ added to both voltages V_1 and V_2 simultaneously. We will see that by changing the voltage v it is possible to observe the same TE, and

¹⁾ e-mail: svysh@rsfq.npi.msu.su

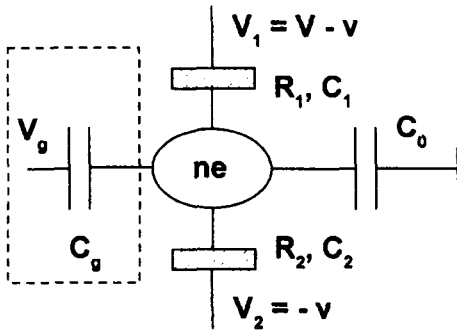

Fig.1. Charge-quantized double-barrier structure. Junctions with tunnel resistances $R_{1,2}$ and capacitances $C_{1,2}$ are shown as boxes. The self-capacitance C_0 of the central island is shown as a capacitor connected to a point with zero potential. The gate with capacitive coupling C_g may be absent from the system

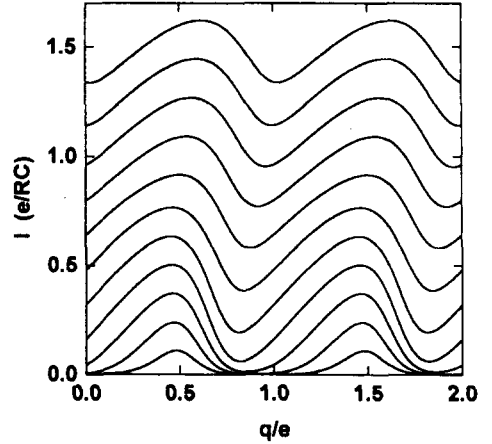

Fig.2. Single-electron transistor effect. Current I , defined by Eq. (4), versus the partial polarization q , defined by Eq. (8), at different transport voltages VC/e , starting at 0.2 at the bottom with increments of 0.2. $k_B T = 0.05 e/C$, $C_1 = 0.7 C$, $C_2 = 0.1 C$, $R_2/R_1 = 10$, $R = R_1 + R_2$

for structures on the nanometer scale the efficiency of this v control is approximately the same as would be expected for the best possible conventional gate.

Thus we are going to exploit an unusual feature of the SET. When it has a gate (and looks like a 3-terminal structure) it in fact has 4 terminals. The effective fourth terminal is an infinitely remote point traditionally viewed as having zero potential. When a SET does not have a regular gate (and looks like a 2-terminal structure), it is effectively a 3-terminal device, and it is still possible to observe the TE, this time with a special voltage setup.

Effective additional gate. The total charge ne confined on the central island (see Fig. 1) determines its electrostatic potential $\varphi(n)$:

$$en + q_b = C\varphi(n) - C_1 V_1 - C_2 V_2 - C_g V_g. \quad (1)$$

Here q_b is a background charge: q_b/C is the contribution to the potential φ of the central island from charged contaminants present in the vicinity of the island.

Eq.(1) implicitly uses the "fourth terminal". The infinitely remote point used in a definition of the self-capacitance [4] is assumed to be at zero potential. The natural choice (employed in Eq.(1)) is to have zero potential on an isolated uncharged body. This choice fixes the gauge. The zero point of the potential is no longer arbitrary, and the value of the potential (and not just of the potential difference) acquires absolute meaning.

In other words, the self-interaction of the central island (measured by the self-capacitance parameter) is equivalent to interaction with a dedicated point of fixed potential. The most natural choice for such a point is at infinity (and the natural choice for the fixed potential value is zero). So the existence of this self-interaction is equivalent to the fact that our system has a very special point with fixed potential. This special point can be regarded as a "hidden" voltage terminal in our system. We will see that the

voltage parameter $-v$ applied to both current terminals is measured relative to precisely this hidden terminal. This can be alternatively regarded as applying a voltage $+v$ to the hidden terminal, which will imitate one additional v voltage-driven gate.

Orthodox approximation. The free-energy costs of increasing (+) or decreasing (-) the initial number n of electrons on the central island due to a single-electron tunneling event ($n \rightarrow n \pm 1$) in junction 1 or 2 are:

$$\begin{aligned} F_{1,2}^{\pm}(n) &= F_f - F_i = \pm e [\varphi(n \pm 1/2)] \mp eV_{1,2} = \\ &= \pm(e/C)(q_b \pm e/2 + en + C_g V_g + \\ &\quad + C_1 V_1 + C_2 V_2 - CV_{1,2}). \end{aligned} \quad (2)$$

where $F_{1,2}^{\pm} < 0$ (> 0) corresponds to an energetically favorable (unfavorable) event. The dissipation of this energy is part of the tunneling event and distinguishes macroscopic tunneling (considered here) from textbook quantum mechanical tunneling. For a given n , the tunneling rates in each junction are expressed [3] by

$$\Gamma_{1,2}^{\pm}(n) = \frac{-F_{1,2}^{\pm}}{e^2 R_{1,2}} \frac{1}{1 - \exp [F_{1,2}^{\pm}/(k_B T)]}. \quad (3)$$

A statistical distribution $p(n)$ of charge states n is established when the external voltages are constant. The current I_i through tunnel i in the direction from V_1 to V_2 equals

$$I_{1,2} = \pm e \sum_n p(n) [\Gamma_{1,2}^+(n) - \Gamma_{1,2}^-(n)], \quad (4)$$

where sum goes over all n for which $p(n) > 0$. Kirchhoff's law, $I_1 = I_2$, holds in the steady state and demands that the distribution $p(n)$ should not change in time. More precisely, simultaneous detailed-balance equations [5] should hold for all n :

$$p(n) \Gamma^+(n) = p(n+1) \Gamma^-(n+1), \quad (5)$$

with $\Gamma^{\pm}(n) = \Gamma_1^{\pm}(n) + \Gamma_2^{\pm}(n)$. For any fixed combination of parameters $C_0, C_g, C_1, C_2, R_1, R_2, V_1, V_2, V_g, q_b$, and T , using Eq.(2) and (3), we can solve Eqs. (5) for the statistical distribution $p(n)$. We can then calculate the current I from Eq. (4) as a function of these parameters.

Periodic modulation of the current. Consider the one-to-one mapping $\{V_1, V_2\} \leftrightarrow \{v, V\}$:

$$V_1 = V - v, \quad V_2 = -v, \quad (6)$$

so that $V_1 - V_2 = V$ always. In experiment this means that the voltages V_1 and V_2 are generated (according to Eq.(6)) by an operational amplifier or computer starting from two independently controlled parameters: V and v . By changing v independently of V and other parameters of the system, we hope to reproduce the TE when the gate is absent completely ($C_g = 0$).

After applying transformation (6) to Eq. (2), we get:

$$F_{1,2}^{\pm}(n) = \pm(e/C)(\pm e/2 + K_{1,2}V + en + q), \quad (7)$$

with $K_1 = -(C_0 + C_g + C_2)$, $K_2 = C_1$, and partial polarization

$$q = q_b + C_g V_g + (C_0 + C_g)v. \quad (8)$$

recall that the four expressions $F_{1,2}^{\pm}(n)$ determine the probabilities $p(n)$, current I , and all other measurable values.

An essential feature of Eq. (7) is that both q and n enter all four forms $F_{1,2}^{\pm}(n)$ in exactly the same combination $en + q$. As long as all other parameters of the system are kept constant, the simultaneous substitutions

$$\{q \rightarrow q + e, \quad n \rightarrow n - 1\} \quad (9)$$

leave the combination $en + q$ invariant. So the whole set of $[F_{1,2}^{\pm}(n), \Gamma_{1,2}^{\pm}(n), \text{ and } p(n)]$ for all n is covariant with the shift (9). From Eq. (4) we see that the current I remains invariant under the change (9). And this just means that the current is periodic (Fig. 2) in q with a period

$$q_{\text{period}} = e. \quad (10)$$

Note that K_1 and K_2 in Eq. (7) are always different. They even have different sign. Therefore, there can be no periodicity in V .

In traditional (3-terminal) experiments a monotonic change of q is achieved through a change of the gate voltage V_g . The resulting current modulation with a period

$$V_{g \text{ period}} = e/C_g \quad (11)$$

is known as the single-electron TE.

Alternatively, the same effect can be obtained if the parameter v is changed with all the other parameters held constant. From Eqs. (8) and (10) we see that in this case current is modulated with a period

$$v_{\text{period}} = e/(C_0 + C_g). \quad (12)$$

If both parameters V_g and v are changed simultaneously, the current is modulated with the period (10).

Two-terminal device. From Eqs. (7) and (8) it is clear that pairs $\{C_g, V_g\}$ and $\{C_0 + C_g, v\}$ play similar roles in SET dynamics. This means that if the system under study lacks a gate C_g completely ($C_g = 0$), one can still study the TE experimentally, but now with the parameter C_0 as the effective gate, the parameter v as the effective gate voltage, and the modulation period v_{period} given by Eq. (12).

It can often happen that an interesting two-terminal double-barrier structure [1] is fabricated in a way which precludes placing a nearby gate with the sufficiently large C_g . Indeed, in demonstrating periodic modulation of the tunnel current one usually needs to restrict the voltages to the range $V_g < 1$ V, just to preserve the mechanical and electrical stability of the systems under study. Larger voltages may cause redistribution of the surrounding charged contaminants (changing the background charge q_b) and trigger processes such as electromigration. To have $V_{g \text{ period}} < 1$ V, we need $C_g > 0.1$ aF. This is hard to achieve for a central island of small dimensions. If a central island has a radius $r \simeq 1$ nm, as in [1, 2], and a gate is separated from it by a distance d , then the gate capacitance can be estimated as $C_g \simeq \epsilon_{\text{eff}}\epsilon_0\pi r^2/d$. To get $C_g < 0.1$ aF, the separation should be $d > 2$ nm (with $\epsilon_{\text{eff}} = 10$). It is very hard to make or find that narrow a separation which is not short-circuited and is not a tunnel junction. Recall that the typical thickness of a tunnel barrier is about 1 nm.

This challenging goal was achieved in [2] by a complicated and unpredictable method of gate fabrication. The authors began with lithographic deposition of a gold gate having

a highly branched form. The gate was isolated from the conducting substrate. Then they covered the structure with a Langmuir film, containing conducting cluster molecules with radius $r \simeq 1$ nm. Some (very few) of the clusters happened to lie on the substrate within a distance $d > 2$ nm from the gate. Such clusters were sought out with a scanning tunneling microscope and were then used as the central island of a SET (substrate-cluster-microscope tip). This SET was successfully modulated by the gate at room temperature. An estimate according to Eq.(11) gave $C_g = 0.2$ aF.

The self-capacitance of a central island with radius $r = 1$ nm can be estimated as $C_0 \simeq \epsilon_{\text{eff}}\epsilon_0 r \simeq 0.1$ aF. And Eq. (12) gives $v_{\text{period}} \simeq 1$ V. In real systems the current leads can screen off some of the environment from the central island, thus reducing C_0 and increasing v_{period} . However, estimates made for known practical setups always gave a reduction of C_0 by a factor of less than 10. Thus from Eq. (12) we can expect a value $v_{\text{period}} \simeq 0.3$ V for the same structure. This means that the authors of [2] might have demonstrated v modulation with a period (12) at the same room temperature, even without fabricating a complicated gate or searching for a cluster molecule which had accidentally stuck at an appropriate position.

Consider a SET with a quantum dot as the central island [1]. Due to spatial quantization of the wave function of an electron confined on the central island, full capacitance C is no longer constant but depends on the charge ne , voltages, temperature, and the bulk and surface properties of the environment [6]. But even with variable C , the energy cost of tunneling depends on the polarization of the central island, and this polarization can be achieved by changing the voltage v in a two-terminal device. Thus charge quantization in a quantum-dot SET can be controlled by this effective gate.

Other mechanisms of electron transport (like co-tunneling [7], or thermal activation above the trapping barrier [8]) may contribute to the current. In either case the current is periodically modulated with respect to the polarization of the central island, which in turn can be achieved by changing either V_g or v .

A similar method can be used to control current through charge-quantized chains of tunnel junctions, in particular, through self-selecting chains of granules in disordered systems [9].

Helpful discussions with F. Ahlers, Y. Nakamura, S. Oda, E. Soldatov, and A. Zorin are gratefully acknowledged. This work was supported in part by the Russian Foundation for Basic Research and the Russian Program for Future Nanoelectronic Devices.

-
1. C.T.Black, D.C.Ralph, and M.Tinkham, *Phys. Rev. Lett.* **76**, 688 (1996).
 2. E.S.Soldatov, V.V.Khanin, A.S.Trifonov et al., *JETP Lett.* **64**, 557 (1996).
 3. D.V.Averin and K.K.Likharev, in *Mesoscopic Phenomena in Solids*, Eds. B.L.Altshuler, P.A.Lee, and R.A.Webb, Amsterdam: Elsevier, 1991.
 4. L.D.Landau and E.M.Lifshitz, *Electrodynamics of Continuous Media*, Oxford: Pergamon Press, 1960.
 5. G.-L.Ingold and Yu.V.Nazarov, in: *Single Charge Tunneling*, Eds. H.Grabert and M. Devoret, New York: Plenum, 1992 (NATO ASI Series B, Vol. 294).
 6. K.Natori, *J. Appl. Phys.* **78**, 4543 (1996).
 7. D.V.Averin and Yu.V.Nazarov, in Ref. [5].
 8. S.V.Vyshenski, *JETP Lett.* **64**, 592 (1996).
 9. S.V.Vyshenski, *JETP Lett.* **61**, 111 (1995).

Edited by Steve Torstveit